

sisuROCK SYSTEMS



sisu **ROCK** *Hyperspectral Core Imaging Station*

SisuROCK is a fully automated hyperspectral imaging instrument for easy, high speed scanning of drill cores and other geological samples. It is capable of imaging a single drill core in a high resolution mode or a whole core box in a high speed scanning mode. Hyperspectral imaging data of a whole core box is acquired in less than 15 s, highly improving productivity in drill core analysis.



Geologically classified SWIR image of a drill core tray. Image collected in a high speed mode with 2 mm resolution. Tray size 132 x 40 cm, image size 1 050 x 320 pixels.

SisuROCK provides an efficient and high throughput production tool for the mining industry and a versatile and flexible analysis tool for geological research applications. SisuROCK applies Specim's state of the art hyperspectral cameras for rapid collection of hyperspectral data from various geological samples.

HOW SISUROCK WORKS

SisuROCK implements high speed pushbroom hyperspectral imaging and is a fully equipped turnkey solution. It consists of sample illumination units and hyperspectral cameras which collect spectral and spatial information from the cores as the core box is automatically moved through the system. Power supplies and the data logging computer are neatly stored in cabinets below the sample table. All this is built in a rugged instrument which is developed to offer easy, rapid and flexible operation.

SisuROCK is capable of handling samples up to 1.5 m in length, 0.65m in width and 50 kg in weight. Once the samples are loaded onto the tray, the data acquisition is initialized from the Windows based data acquisition computer. Each scan automatically starts with built-in calibration measurements, which include a dark reference and reference image from a known reflectance target. With this calibration data, the raw spectral data collected from the samples, can be turned into system independent reflectance or absorbance data which includes the mineral specific spectral signatures. The operator can complement each image data file with additional metadata like operator id, core depth, core box number and additional description for instance on the mine or measurement campaign.

Based on mineral specific reflectance data, prediction models to qualify and quantify the measured drill cores and other geological samples can be created.

Key benefits

- Turnkey hyperspectral drill core imaging
- Automatic core box scanning
- High speed production instrument for exploration projects
- Objective and consistent data across the entire project area
- No special sample preparation
- Versatile tool for geological research
- High spatial and spectral resolution with two options: SWIR spectral imaging with high resolution RGB and SWIR+VNIR spectral imaging
- Thermal imaging option available



PERFORMANCE AND PRODUCTIVITY

SisuROCK is capable of providing the data collection rate required in large exploration and industrial projects. Imaging takes place with high spatial resolution for optimal sample structural detail, and with high spectral resolution providing discrimination of mineral spectral signatures.

OPTIONS FOR VARIOUS APPLICATION REQUIREMENTS

SisuROCK can be equipped with one or two cameras. The default camera is Specim's SWIR Spectral Camera. The SWIR range is rich in mineral spectral signatures and is therefore the most important spectral range for geological analyses applications. The SWIR hyperspectral camera acquires images with 320 spatial pixels and 256 spectral bands, and covers wavelengths 970-2500 nm. The SWIR camera can be accompanied with either a RGB camera or a VNIR spectral camera. The RGB camera offers 4000 spatial pixels producing high resolution color imagery when textural information about the samples is required. The VNIR spectral camera provides continuous spectral information over the range 400-1000 nm.

An average data collection rate of 1 200 meters of core per day was achieved in an exploration project, where SisuROCK was operated in the full core tray mode with spatial resolution of 2 mm. Hyperspectral data from total of 17 000 meters of core was collected in two weeks. The cost per core meter for hyperspectral data collection and mineralogical analysis appeared to be a very minor cost component in the overall exploration cost per core meter.

THERMAL IMAGING OPTION

SisuROCK can be equipped with a thermal imager. This standalone add-on LWIR (8-12µm) hyperspectral camera provides an efficient tool for additional mineral recognition. Together with the SWIR range it covers the majority of the existing minerals.

For further information contact the manufacturer.

Performance specifications

	SWIR	VNIR	RGB
Spectral range	970 – 2 500 nm	400 - 1 000 nm	Not applicable
Number of spectral bands	256	96	3
Pixel size on target (†)	HR: 0.2 mm	HR: 0.09 mm	HR: 0.016 mm
	HS: 2.0 mm	HS: 0.64 mm	HS: 0.16 mm
Number of pixels/image line	320	1000	4 000
Scan rate	HR: 20 mm / s	HR: 15 mm / s	HR: 20 mm / s
	HS: 200 mm / s	HS: 110 mm / s	HS: 200 mm / s
Scan time for single core box (‡)	15 s	20 s	15 s
Max sample size	1 500 x 640 x 200 mm (L x W x T), 50 kg		
Cooling requirements	No external cooling required. Air conditioned room recommended.		
Operating conditions	Laboratory type environment. Small amount of dust accepted.		
Operating temperature	0 to +40°C, non-condensing		
Operating voltage	110 to 220 V and 50/60 Hz clean power supply		
Output data format	BIL file format, ENVI/Evince compatible		
Instrument calibration	Spectrally calibrated data. Normalization		White balance

(† HR stands for High Resolution mode for single core measurement

HS stands for High Speed mode for single core box measurement.

(‡ 1.5 m long core box. Including calibration measurements.

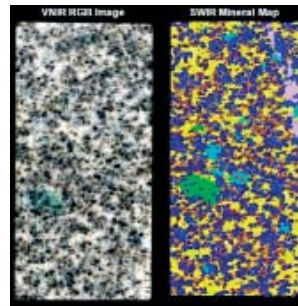

- Pyroxene-Phyllosilicate
- Orthopyroxene
- Clinopyroxene
- Talc-Pyroxene
- Plagioclase
- Prehnite
- Pyroxene-Feldspar

Sample of a single drill core, imaged in a high resolution mode with 0.2 mm resolution.

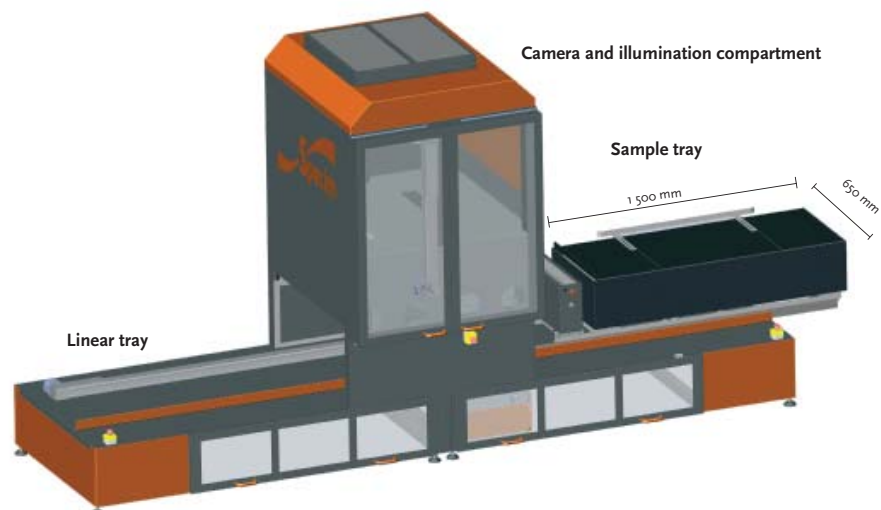

SPECIM IS A WORLD LEADING COMPANY for hyperspectral imaging instruments, from UV through VNIR and SWIR up to LWIR (long wave infrared).

We provide ImSpector imaging spectrographs, Spectral Cameras and hyperspectral imaging solutions to a rapidly increasing number of industrial OEM customers and a large scientific clientele. SPECIM'S AISA FAMILY of airborne hyperspectral sensors provides market leading solutions for remote sensing, from small UAV systems to full featured commercial, research and military remote sensing tools.

Our hyperspectral products are known for the highest performance at the lowest budget in the market. They are used in an increasing range of demanding applications like color, Process Analytical Technology (PAT), life sciences, chemical imaging, military and security.



Spectral Imaging Ltd.
POB 110
Teknologiantie 18 A
FIN-90571 Oulu, Finland

www.specim.fi