

spectral camera PFD

Hyperspectral camera operating in the VIS and VNIR ranges of 380-800 nm and 400-1000 nm. With its high resolution, high image rate, flexible wavelength selection, and rugged structure, Spectral Camera PFD is an excellent tool for industrial measurements.



Cased Spectral Camera PFD



OEM Spectral Camera PFD

Spectral Camera is an imaging spectrometer, an integrated combination of our ImSpector imaging spectrograph and an area monochrome camera. It works as a push-broom type line scan camera and provides full, contiguous spectral information for each pixel.

The Spectral Camera PFD consists of an ImSpector V8E or V10E for the wavelength range 380-800 nm or 400-1000 nm, respectively, and a high speed CMOS detector. The transmission diffraction grating and lens optics used in the spectrograph provide a high quality, low

distortion image that is designed to fulfill the most demanding specifications.

This Spectral Camera provides the flexibility and high speed acquisition required in the industrial QC applications. Combination of multiple Region-Of-Interests and binning gives a possibility for the optimal system setup and control for the user. Full spectral range can be acquired with 180 fps at 1312 spatial locations. By selecting partial spectral ranges, speed up to 1000 fps can be achieved.

Applications

- Quality control
- Food and vegetation research
- On-line sorting and quality monitoring
- Plant and vegetation research
- Environmental monitoring
- Counterfeit detection



Performance Specifications

SPECTRAL CAMERA	V8E	V10E
Optical characteristics		
Spectrograph	V8E	V10E
Spectral range	380-800	400-1000
Spectral resolution (30 µm)	2.0nm	2.8nm
Spectral sampling	0.59 - 4.75 nm/pixel *)	0.78 - 6.27 nm/pixel *)
Spatial resolution	RMS spot size <9µm	
Aberrations	Insignificant astigmatism, keystone or smile	
Numerical aperture	F/2.4	
Slit width options	30 µm (18, 50, 80, 150 µm)	
Effective slit length	10.50 mm	
Total efficiency (typical)	> 50% independent on polarization	
Stray light	< 0,5% /halogen lamp, 590nm LPF)	
Electrical characteristics		
Sensor	CMOS	
Pixels in full frame	1312 (spatial) x 1024 (spectral)	
Active pixels	1312 (spatial) x 768 (spectral)	
Pixel pitch	8.0 µm	
Camera output	Digital 12 bit	
Interface	Base CameraLink	
Camera control	CameraLink	
Frame rate	65 fps (full frame) up to 180 fps (with binning)	
Additional features	Asymmetric binning up to x 8 Multiple Region-of-Interest either in spatial or spectral direction	
Exposure time range	0.1 - 100 ms	
Power consumption	< 5W	
Input voltage	12V (OEM), 24V (cased)	
Environmental characteristics		
Storage	-20... +50 °C	
Operating	+5... +40 °C non-condensing	
Mechanical characteristics		
	OEM	Cased
Size (L x W x H)	231 x 80.5 x 78 mm	330 x 85 x 90 mm
Weight	1.8 kg	2.7 kg
Body	Anodized aluminium with mounting screw holes	
Lens mount	Standard C-mount	
User adjustments	None	
Shutter	Optional	Yes, with USB control

*) Adjustable by spectral binning.

ACCESSORIES

SPECIM can provide various accessories for the Spectral Cameras to broaden their applicability.

- **Fore objective lenses** which are designed to provide the optimal image and spectral quality across the full spectral range of the Spectral Camera.

Lens	Focal length	FOV
OLE 18,5	18,5 mm	31,7 degrees
OLE 23	23 mm	25,7 degrees
OLE 140	140 mm	4,3 degrees

- **Collection fiber optics** to convert the camera into a multiple point spectrometer. All the points are measured simultaneously without a moving multiplexer.
- **Mirror Scanner or rotating stage** for scanning static targets and outdoor scenes, or with **X-stage sample mover** for desktop and microscope applications.

SPECTRALDAQ SOFTWARE

SPECIM Spectral Camera PFD is supported by SpectralDAQ software, which allows:

- data acquisition and saving data in the hard disk
- to set camera parameters
- image visualization in real time

Datacubes are saved in ENVI compatible format that allows further processing by several software packages for hyperspectral data processing.

OEM camera, bottom view

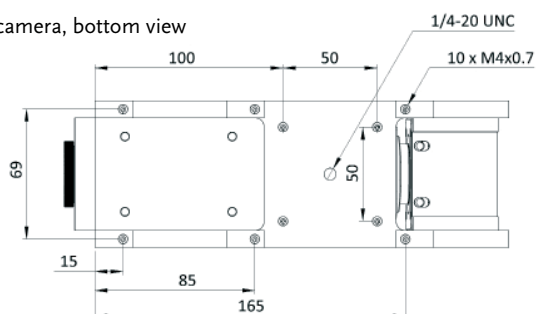

OEM camera, side view

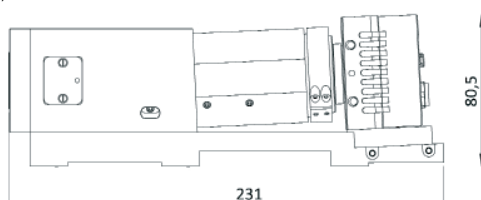

Cased camera, bottom view

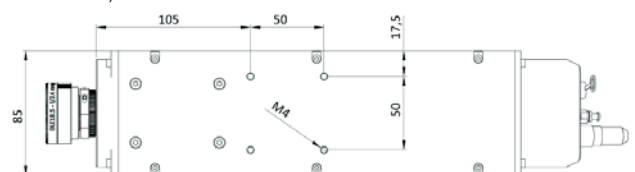

Cased camera, side view

