

IsolatIR™ Spectroscopy Glovebox™



Patent Pending

Spectroscopy Glovebox

Ambient humidity and carbon dioxide play a significant role in infrared spectroscopy. Single beam spectra of even the best purged instrument have substantial water and CO₂ bands. In the practice of infrared spectroscopy, the background is measured under similar conditions, and the hope is that by dividing the sample and background spectra, the water and CO₂, which should be the same in both cases, will be cancelled out. In real practice however, this is not the case. Due to small variations of the concentrations of water in the air over time, the ratioed spectra will still have residual water bands. In most analysis, the region where CO₂ absorbs is less important, but the residual and always varying water bands are more than a nuisance, they may be the final limit to detecting small analytical bands in the region where water vapor absorbs.

Most modern FTIR instruments are purgeable with dry gas. Continuous supply dry air modules are available. For smaller tasks or intermittent purging, nitrogen or argon gas cylinders can be used and liquid nitrogen can also be boiled off and utilized under certain circumstances. The purging with dry or close to dry gases works well in the closed compartments of the FTIR, the humidity level eventually stabilizes in those compartments. The sample compartment however, still represents the problem in that the air is exchanged during sample placement. The purging is an exponential function due to the mixing of the ambient air with the dry gas, thus the dry condition can almost never be achieved. Sample compartments, in general, are also less well sealed, further compromising the achievable purge performance.

Middleton Research has designed the IsolatIR™ to overcome the limitations of the varying ambient conditions between background and sample measure-

ment. The IsolatIR™ module is a sealed compartment with infrared windows for the light to pass through the enclosed chamber. The module can be placed directly in the FTIR spectrometer's sample compartment, providing the appropriate mechanical and optical interface to the FTIR instruments. The complete sampling accessory is placed inside the IsolatIR™, the pinned alignment assuring reproducible positioning of the accessories. The IsolatIR™ is equipped with dual glove access, thus the sample placement within the isolated chamber can be done without opening the enclosure, thus assuring the same airspace around sample and background. With multiple samples, the process is the same, a number of samples can be placed in the chamber at one time.

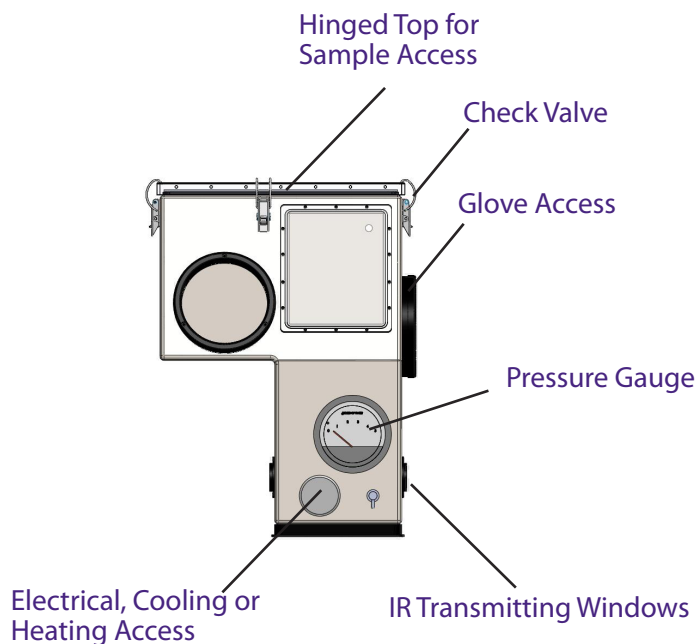

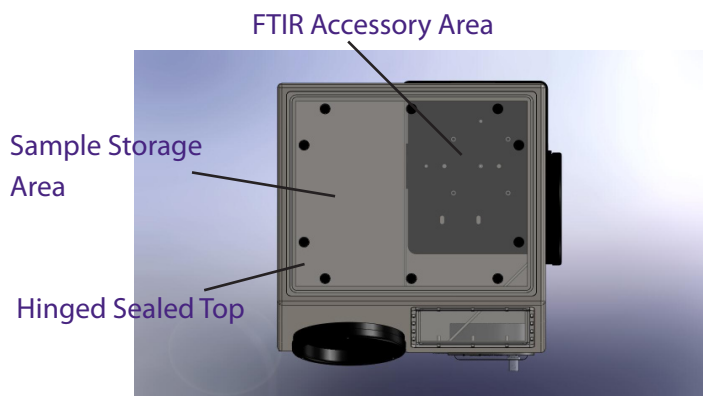

Improved Baseline

The most common problem with analyzing a small volume of materials or minor components is moisture variation in the ambient laboratory air that produces large positive or negative water vapor bands in the infrared spectrum, in many cases, just around the important bands from the analyte. The IsolatIR™ keeps the samples in an unchanging, sealed environment, thus allowing maximum control of the atmosphere around the sample throughout background and sample measurements. Multiple samples can be placed inside the sealed chamber of the IsolatIR™ and moved into sampling position using the dual glove access from outside, without opening the compartment.

Challenging Samples

The IsolatIR is designed to hold an overpressure or reduced pressure up to +/- 3" water, for challenging samples. The pressure is monitored with a very sensitive low-pressure Magnahelic™ gauge.

Positive Pressure

The IsolatIR™ allows two different kinds of challenging samples to be measured. Samples that are sensitive to any component of the ambient air, such as oxygen, carbon dioxide or moisture, may have to be kept not only in a sealed enclosure with the outside air excluded, but for even more safety margin may have to be kept under a slight overpres-

sure, so the outside atmosphere has even less chance to penetrate the isolated chamber. With a slow, steady supply of neutral gas, the IsolatIR™ can be kept at the pressure level allowed by the check valve, situated at the back side of the enclosure. The standard check valve has a nominal 3" water break pressure, thus with a steady flow of fresh gas, the enclosure will be kept at that pressure.

Negative Pressure

Samples that may emit vapors that could be harmful, could be isolated at ambient pressure, or a small negative pressure can be applied for additional security. The special configuration would require a pressure gauge with negative pressure range and an inverted check valve. Without the inverted check valve, the vacuum pump could reduce the pressure below the nominal -3" water pressure and harm the pressure gauge, or in extreme case damage the enclosure which is not designed to handle high vacuum. With the proper check valve in place, a small vacuum can be maintained to keep undesirable substances inside the enclosure.

Please note that acidic, alkaline and toxic materials are different in their toxicity and their effects on the environment, equipment and on the personnel handling them. Middleton Research does not recommend the IsolatIR™ for highly toxic materials, nor assume any responsibility for any consequences of using them in conjunction with Middleton Research products.

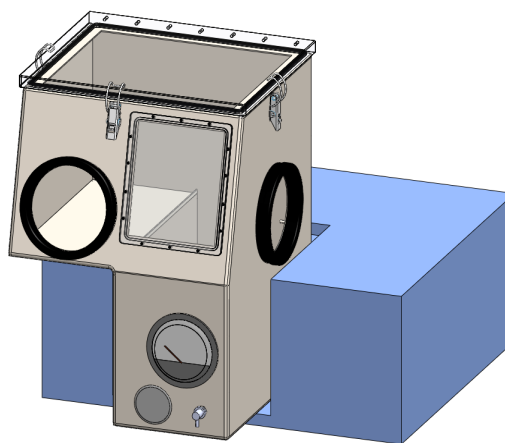

Specifications and Ordering Information

Enclosure Access: 2 gloves, 90 degrees position
 Compatibility: Most major FTIR make and model
 Accessories: Most major FTIR accessories
 Optical height: 2.5" from base of IntegratIR
 Operating Pressure Range: +/- 3 inches of water

MRC-901-001 IsolatIR™ Glovebox for FTIR spectrometers