

MWIR SPECTROGRAPH 3000 – 5000 nm

The MWIR spectrograph is designed for the 3 - 5 μm range. It is intended to explore and remotely identify solids, liquids and gases in the C-H, O-H, N-H stretching vibration region. At this time, these spectrographs are available only for integration with certain camera types. For custom integration to your camera, please contact Middleton Research.

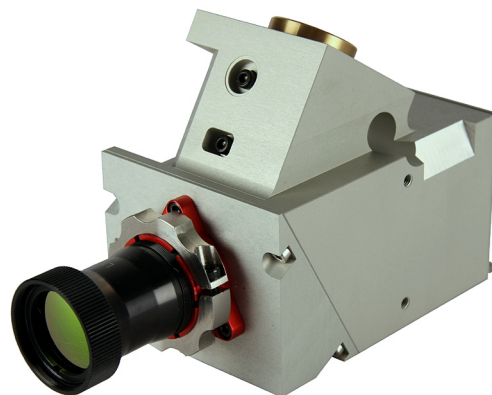
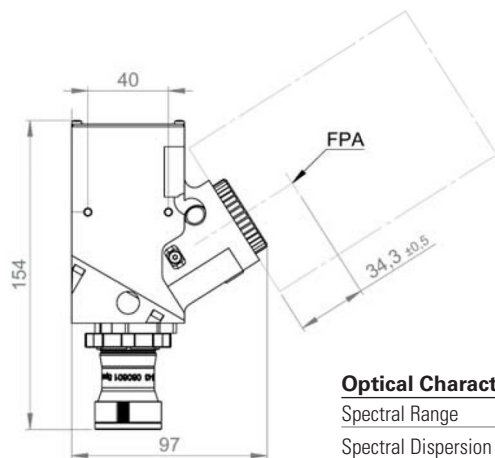

Optical Characteristics	M50M
Spectral Range	3000 - 5000 nm
Spectral Dispersion	560 nm/mm
Spectral Resolution	35 nm
Spatial Resolution	RMS spot radius < 60 μm
Image Size (Spectral x Spatial)	3.57 x 9.6 mm
Numerical Aperture	F/2.0
Optical Input	Standard
Average Diffraction Efficiency	> 65%
Transmission of Optics	> 65%
Stray Light	< 0.5% (halogen lamp, 1400 nm long-pass filter)
Slit Width, default	120 μm
Slit Length	19 mm
Magnification	1:2

Aberrations	
Bending of Spectral Lines Across Spatial Axis	Smile < 2 μm (0.056%)
Bending of Spatial Lines Across Spectral Axis	Keystone < 4 μm (0.042%)

Mechanical Characteristics	
Body	Aluminum casting
Size (W x H x L)	60 x 97 x 154 mm
Weight	770 g
Lens Mount	Custom
Camera Mount	Custom

* This product line is under development. The above specifications may change without notice.

MWIR Spectrographs Ordering Information

Part Number	Description	Product Name
MRC-305-006-01	ImSpector Enhanced MWIR Spectrograph. M50M, 120 μm slit	ImSpector M50M