



LENSES

objective fore lenses

Middleton Research provides specifically designed, high quality fore lenses, optimized to produce uniform and high performance images in the broad spectral ranges covered by hyperspectral imaging systems. All of the lenses offered in this catalog employ broadband anti-reflective (AR) coatings to minimize stray light and glare. Lens adjustments are locked to withstand harsh operating environments. Hyperspectral lenses, in general, have very good chromatic corrections in the stated operating wavelength range.

Lenses are offered in standard and enhanced series. While the standard series lenses have minimal spatial distortion in the order of the camera pixels, the Enhanced Series lenses from Specim Ltd have, at most, sub-pixel distortion in both dimensions. The optical performance of the enhanced lenses is matched to the performance of the inner optics of the spectrographs. Therefore, when selecting a lens for a hyperspectral system, consider an enhanced series lens first, for best performance.

The following factors will determine lens selection: wavelength region, working distance and field of view, each of which is explained here in greater detail.

Wavelength Region

In order to obtain the best chromatic and spatial profiles, the lenses offered in this catalog are composed of a variety of different materials and contain multiple optical elements. Lens materials and coatings are optimized for specific wavelength regions. To determine the best lens to use, it is important to know the full spectral range of the specific application.

This catalog offers a wide array of lenses specific to particular UV, visible, VNIR, NIR, SWIR, MWIR and LWIR regions. Some of the lenses work effectively across more than one wavelength range. The UV lenses are useful from 200-410 nm. For the visible range, high magnification lenses are available. The VNIR range is a wider wavelength range than the visible, therefore special lenses are offered in this catalog for the VNIR region. There are also NIR lenses that are useful from 1000-1700 nm and SWIR lenses that are optimized for the 1000-2500 nm region. SWIR lenses can also be used for the NIR wavelength region because they are both spatially- and color-corrected for the entire region, although they are more complex and, therefore, more expensive than the NIR lenses. Additionally, a number of dedicated lenses are designed specifically for our MWIR and LWIR hyperspectral cameras.

Commercial video lenses are optimized for the visible range and are usually coated for maximum throughput in the visible range only. Even though they may transmit light in the NIR or SWIR ranges, commercial visible range video lenses produce a large spatial and chromatic distortion, rendering them ineffective in these ranges.

Working Distance

Working Distance (WD) is defined as the distance from the end of the camera lens to the object or area under surveillance. The minimum working distance is the shortest distance a lens can be placed to the sample to still obtain a sharp image. Sufficient working distance is necessary to manipulate or exchange the sample. Most hyperspectral lenses can be focused from infinity to the minimum focal distance, as defined in the lens data tables. Notable exceptions are the close-up lenses which can be focused in a narrow distance range. In this case, the working distance is defined as the range in which the limited focus adjustment creates a sharp image.

Field of View

The field of view is expressed in angles and defined as the size of the area to be imaged. The field of view is determined by the working distance, slit width, camera sensor size, and the focal length of the lens.

Calculation of Focal Length

Lenses in this catalog are listed according to their focal length. Simple formulas are shown below for calculating the optimum focal length lens from the working distance, the dimensions of the object, and the dimensions of the slit. Two dimensions of the object are used for determining the different parameters of the camera setup and lens selection. The length of the object determines the macro dimensions of the setup and lens selection. The width of the object, which is in the direction of the slit arrangement, can be used to determine the desired slit width. The slit width specifies how much of the sample is actually seen at any one frame of the push-broom



camera system. Please note that the slit width also determines the optical resolution achievable. The following equations relate the known object size, desired resolution (length and width of the imaged line), and working distance to the required focal length and slit dimensions.

$$f = \frac{L_s D}{L_i} \quad \text{or} \quad f = \frac{W_s D}{W_i}$$

In the above equations, f = focal length of lens, D = working distance, L_s = length of slit, W_s = width of slit, L_i = length of imaged line, W_i = width of imaged line

Working distance is measured from the front of the lens to the viewed object; whereas, object to image distance is measured from the sensor to the object. To calculate the lens focal length required, the working distance must be used, not the image distance. An optical setup example is shown. Note that in this configuration, the object's width could be as large as 195.56 mm and, assuming a typical 30 μm slit in the camera, a 0.67 mm spatial resolution (width of viewing line) would be achievable.

A small table with examples of working distance vs. object size is included at the end of each lens specifications table to help identify and select the proper lens and mounting distance for different applications.

NOTE: For hyperspectral cameras, the lens must focus on the slit, and the slit width determines the width of the sample area viewed by the camera. The actual dimensions of the slit widths to be used for the calculations are noted in the camera and spectrograph chapters. In the slit length direction, however, the determining factor for the length of the image line is the sensor dimension, not the physical slit length, because the sensor is usually shorter than the slit. In the case of a 2/3" sensor, the slit length is limited to 8.8 mm, and this length should be used for the calculations. See the Glossary for further explanation.

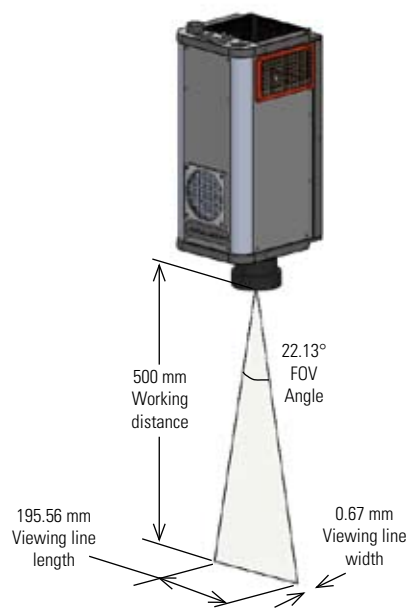

Mounting

C-Mount is a standardized lens interface most commonly used by camera manufacturers. Most spectrographs and cameras in this catalog, therefore, offer C-Mount interface on the lens side to accommodate the large variety of commercially available lenses.

The focal distance from the camera side flange to the sensor is 17.526 mm. The standard threading for connecting the C-Mount lens to a camera or spectrograph is 1"-32UN2A.

While C-Mount is the most widely used standard mounting in the visible video industry, different mounting arrangements may be required due to larger sensor sizes, different wavelength ranges and other special features. For larger format cameras and for thermal cameras, special mounts are usually used and those are marked in the respective sections.

Telecentric Lenses

A telecentric lens is a special class of lenses having negligible or no distortion with the object being slightly above or below the focus. When using conventional lenses, the image size of an object changes depending on the location of the object relative to the lens focus. The lack of distortion is the result of the light collected from or projected parallel with the optical axis. Telecentric lenses are used extensively in machine vision metrology because the edges of objects must be seen in undistorted sharp focus so that dimensions of the object can be established from the image with a high degree of accuracy. In hyperspectral imaging, telecentricity is useful because some focal plane array cameras have micro-lens arrays that work best with the beam falling perpendicular to the FPA. Telecentric design is therefore a significant optical feature of the spectrographs offered in this catalog. Further explanation is found in the Glossary.

Lens Accessories

Spectral flattening filters can be attached to the lenses; for more details, refer to the filters section of the Accessories chapter.

UV LENSES

The UV objective fore lens is optimized for the ultra-violet wavelength region, 200 - 410 nm. It is optimized for the optics of the Enhanced Series spectrograph, ImSpector UV4E.

Optical Characteristics	OLUV28
Focal Length	28.3 mm
F-number	3.5
Spatial Image Size (max)	18 mm
Transmission	> 75%
Minimum Working Distance *	25 cm

Mechanical Characteristics	
Dimensions	39.5 mm x ø 37.5 mm
Body Material	Anodized Aluminum
Mount	C-mount



Dimensions of Imaged Line (LxW) at Select Working Distances (D)

Field of View angle (degrees) **	17.7	
D = 300 mm [11.81 in]	L=	93.29
	W=	0.32
D = 500 mm [19.69 in]	L=	155.48
	W=	0.53
D = 750 mm [29.53]	L=	233.22
	W=	0.80
D = 1000 mm [39.37]	L=	310.95
	W=	1.06
D = 1500 mm [59.06]	L=	466.43
	W=	1.59
D = 2000 mm [78.74 in]	L=	621.91
	W=	2.12
D = 3000 mm [118.11 in]	L=	932.86
	W=	3.18
D = 1 km [3280 ft] ***	L=	310.95
	W=	1.06

* Full field of view angle and sharp focus may not be achieved if distance is shorter than the given minimum working distance.

** Default slit width (50 µm) for UV4E ImSpector used for calculations. Standard 2/3" detector limits effective slit length to 8.8 mm.

*** Length and width at 1 km calculated in meters [m].

UV Lens Ordering Information

Part Number	Description	Product Name
MRC-308-004-01	UV Lens, C-Mount, 28mm, f/3.5 (200 - 410 nm)	OLUV28

HIGH MAGNIFICATION VISIBLE LENSES

Middleton Research offers a selection of high magnification lenses for the visible and VNIR wavelength regions. They offer high magnification with fixed long working distances (92mm are shown) while maintaining high resolution and less than 0.14% distortion. The lenses described here in detail have one select working distance; other options are available for shorter or longer working distances as well as different magnifications. Please contact Middleton Research to discuss the lens options for your particular application.



Hyperspectral image of currency



High magnification precise eye lens

Optical Characteristics	OLMAG10X05X	OLMAG10X10X	OLMAG10X20X
Magnification	0.9 X	1.8 X	3.6 X
F-number	4.5	4.5	4.5
Transmission	> 70%	> 70%	> 70%
Nominal Working Distance	92 mm	92 mm	92 mm

Mechanical Characteristics			
Dimensions	Ø 28.6 x 107 mm	Ø 28.6 x 107 mm	Ø 28.6 x 107 mm
Body Material	Anodized Al	Anodized Al	Anodized Al
Mount	Anodized Al	Anodized Al	Anodized Al

Length of Imaged Line at Nominal WD			
WD = 92 mm	9.8 mm	4.9 mm	2.4 mm

High Magnification Visible Lenses Ordering Information		
Part Number	Description	Product Name
MRC-211-001-08	High Magnification Precise Eye Visible Lens, C-Mount, 0.9X Magnification, 92 mm nominal WD	OLMAG10X05X
MRC-211-001-09	High Magnification Precise Eye Visible Lens, C-Mount, 1.8X Magnification, 92 mm nominal WD	OLMAG10X10X
MRC-211-001-10	High Magnification Precise Eye Visible Lens, C-Mount, 3.6X Magnification, 92 mm nominal WD	OLMAG10X20X

VNIR – ENHANCED SERIES

The Enhanced Series VNIR objective fore lenses are optimized for the visible to near-infrared wavelength region, 400 – 1000 nm. They have a telecentric output and are optimized for the optics of the Enhanced Series spectrograph, ImSpector V10E. The Enhanced Series also includes lenses for large sensors.

Optical Characteristics	OLE18.5	OLE23	OLE140
Focal Length	18.5 mm	23 mm	140 mm
F-number	2.4	2.4	2.4
Spatial Image Size (max)	12.4 mm	14.4 mm	12.4 mm
RMS Spot Diameter	17.4 μ m	15.4 μ m	10 μ m
Transmission	> 85%	> 85%	> 85%
Minimum Working Distance *	30 cm	30 cm	10 cm

Mechanical Characteristics			
Dimensions	48 mm x ϕ 53 mm	43 mm x ϕ 41 mm	162 mm x ϕ 65 mm
Body Material	Anodized Aluminum	Anodized Aluminum	Anodized Aluminum
Mount	C-mount	C-mount	C-mount

Dimensions of Imaged Line (LxW) at Select Working Distances (D)

Field of View angle (degrees) **		26.8	21.7	3.6
D = 100 mm [3.94 in] *	L=	--	--	6.29
	W=	--	--	0.02
D = 300 mm [11.81 in]	L=	142.70	114.78	18.86
	W=	0.49	0.39	0.06
D = 500 mm [19.69 in]	L=	237.84	191.30	31.43
	W=	0.81	0.65	0.11
D = 750 mm [29.53]	L=	356.76	286.96	47.14
	W=	1.22	0.98	0.16
D = 1000 mm [39.37]	L=	475.68	382.61	62.86
	W=	1.62	1.30	0.21
D = 1500 mm [59.06]	L=	713.51	573.91	94.29
	W=	2.43	1.96	0.32
D = 2000 mm [78.74 in]	L=	951.35	765.22	125.71
	W=	3.24	2.61	0.43
D = 3000 mm [118.11 in]	L=	1427.03	1147.83	188.57
	W=	4.86	3.91	0.64
D = 1 km [3280 ft] ***	L=	475.68	382.61	62.86
	W=	1.62	1.30	0.21

* Full field of view angle and sharp focus may not be achieved if distance is shorter than the given minimum working distance.

** Default slit width (30 μ m) chosen for calculations. Standard 2/3" detector limits effective slit length to 8.8 mm.

*** Length and width at 1 km calculated in meters [m].



When choosing between the VNIR Enhanced Series lenses, consider the size of the samples and the desired magnification. The VNIR Enhanced Series lenses offer a range of focal lengths (9 – 140 mm) and field of view angles (4 – 52°).



OLE 18.5



OLE 23



OLE 140

VNIR - Enhanced Series Lenses Ordering Information		
Part Number	Description	Product Name
MRC-308-002-03	VNIR Enhanced, C-Mount Lens. 18.5 mm, f/2.4, C-mount, E-series, 400-1000nm	OLE18.5
MRC-308-002-04	VNIR Enhanced, C-Mount Lens. 23 mm, f/2.4, C-mount, E-series, 400-1000nm	OLE23
MRC-308-002-05	VNIR Enhanced, C-Mount Lens. 140 mm, f/2.4, C-mount, E-series, 400-1000nm	OLE140

VNIR – STANDARD SERIES

The Standard Series VNIR objective fore lenses are optimized for the visible to near-infrared wavelength region, 400 – 1000 nm. They were developed for 1", 2/3" or smaller sensors, thus are a good match for most of the visible and VNIR spectrographs in this catalog. The M-Series spectrograph allows larger sensors and requires a larger, non-C-Mount lens.

Optical Characteristics	OL8	OL12	OL17	OL23	OL35	OL50
Focal Length	8.3 mm	12.7 mm	17.6 mm	22.5 mm	34.9 mm	50 mm
F-number	1.4	1.4	1.4	1.4	1.9	1.4
Spatial Image Size (max)	12 mm	12 mm	12 mm	12 mm	12 mm	22 mm
Transmission	> 80%	> 80%	> 80%	> 80%	> 80%	--
Minimum Working Distance *	5 mm	20 mm	70 mm	115 mm	310 mm	--

Mechanical Characteristics

Dimensions	ø 52 x 36.2 mm	ø 52 x 43.8 mm	ø 52 x 36.8 mm	ø 52 x 40.5 mm	ø 52 x 38.5 mm	ø 52 x 74.2 mm
Body Material	Anodized Al	Anodized Al	Anodized Al	Anodized Al	Anodized Al	Anodized Al
Mount	C-Mount	C-Mount	C-Mount	C-Mount	C-Mount	C-Mount

Dimensions of Imaged Line (LxW) at Select Working Distances (D)

Field of View angle (degrees) **	55.9	38.2	28.1	22.1	14.4	10.1
D = 100 mm [3.94 in] *	L= 106.02 W= 0.36	69.29 0.24	50.00 0.17	39.11 ** 0.13 **	-- --	-- --
D = 300 mm [11.81 in]	L= 318.07 W= 1.08	207.87 0.71	150.00 0.51	117.33 0.40	75.64 0.26	52.80 0.18
D = 500 mm [19.69 in]	L= 530.12 W= 1.81	346.46 1.18	250.00 0.85	195.56 0.67	126.07 0.43	88.00 0.30
D = 750 mm [29.53]	L= 795.18 W= 2.71	519.69 1.77	375.00 1.28	293.33 1.00	189.11 0.64	132.00 0.45
D = 1000 mm [39.37]	L= 1060.24 W= 3.61	692.91 2.36	500.00 1.70	391.11 1.33	252.15 0.86	176.00 0.60
D = 1500 mm [59.06]	L= 1590.36 W= 5.42	1039.37 3.54	750.00 2.56	586.67 2.00	378.22 1.29	264.00 0.90
D = 2000 mm [78.74 in]	L= 2120.48 W= 7.23	1385.83 4.72	1000.00 3.41	782.22 2.67	504.30 1.72	352.00 1.20
D = 3000 mm [118.11 in]	L= 3180.72 W= 10.84	2078.74 7.09	1500.00 5.11	1173.33 4.00	756.45 2.58	528.00 1.80
D = 1 km [3280 ft] ***	L= 1060.24 W= 3.61	692.91 2.36	500.00 1.70	391.11 1.33	252.15 0.86	176.00 0.60

* Full field of view angle and sharp focus may not be achieved if distance is shorter than the given minimum working distance.

** Default slit width (30 µm) chosen for calculations. Standard 2/3" detector limits effective slit length to 8.8 mm.

*** Length and width at 1 km calculated in meters [m].



When choosing between the VNIR Standard Series lenses, consider the size of the samples and the desired magnification. The VNIR Standard Series offers a range of focal lengths (8 – 50 mm) and field of view angles (10° – 58°). For remote sensing or field applications, a larger field of view angle is usually preferable.

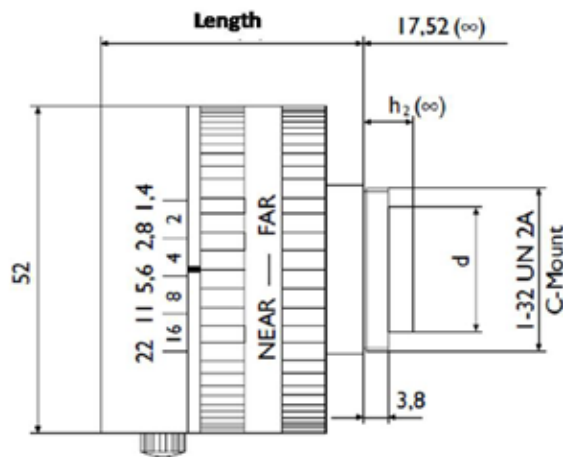

Typical VNIR Standard Series lens mounting and dimensions

VNIR - Standard Series Lenses Ordering Information		
Part Number	Description	Product Name
MRC-308-001-01	VNIR Standard, C-Mount Lens. 8 mm, f/1.4, C-mount, 400-1000nm, 12 mm image	OL8
MRC-308-001-02	VNIR Standard, C-Mount Lens. 12 mm, f/1.4, C-mount, 400-1000nm, 12 mm image	OL12
MRC-308-001-03	VNIR Standard, C-Mount Lens. 17 mm, f/1.4, C-mount, 400-1000nm, 12 mm image	OL17
MRC-308-001-04	VNIR Standard, C-Mount Lens. 23 mm, f/1.4, C-mount, 400-1000nm, 12 mm image	OL23
MRC-308-001-05	VNIR Standard, C-Mount Lens. 35 mm, f/1.9, C-mount, 400-1000nm, 12 mm image	OL35
MRC-308-001-06	VNIR Standard, C-Mount Lens. 50 mm, f/1.4, C-mount, 400-1000nm, 22 mm image	OL50

NIR LENSES

The NIR objective fore lenses are optimized for the near-infrared wavelength region, 900 – 1700 nm. The Enhanced SWIR lenses on the following pages are also optimized for use in the NIR region.

When choosing between the NIR lenses, consider the desired magnification. The lenses in the NIR series offer a range of focal lengths (8 – 50 mm) and have field of view angles between 10° and 58°.



Optical Characteristics	OLN8	OLN12	OLN16	OLN25	OLN35	OLN50
Focal Length	8 mm	12 mm	16 mm	25 mm	35 mm	50 mm
F-number	1.4	1.4	1.4	1.4	1.4	1.4
Transmission	> 75%	> 75%	> 75%	> 75%	> 75%	> 75%
Minimum Working Distance *	10 cm	30 cm	30 cm	30 cm	30 cm	50 cm

Mechanical Characteristics

Dimensions	58mm x ø 57mm	52mm x ø 42mm	53mm x ø 42mm	43mm x ø 42mm	43mm x ø 42mm	48mm x ø 47.5mm
Body Material	Anodized Al	Anodized Al	Anodized Al	Anodized Al	Anodized Al	Anodized Al
Mount	C-mount	C-mount	C-mount	C-mount	C-mount	C-mount

Sample Object Sizes at Different Chosen Working Distances

Field of View angle (degrees) **	61.9	43.6	33.4	21.7	15.6	11.0
D = 100 mm [3.94 in] *	L= 120.00 W= 0.38	-- --	-- --	-- --	-- --	-- --
D = 300 mm [11.81 in] *	L= 360.00 W= 1.13	240.00 0.75	180.00 0.56	115.20 0.36	82.29 0.26	-- --
D = 500 mm [19.69 in]	L= 600.00 W= 1.88	400.00 1.25	300.00 0.94	192.00 0.60	137.14 0.43	96.00 0.30
D= 750 mm [29.53]	L= 900.00 W= 2.81	600.00 1.88	450.00 1.41	288.00 0.90	205.71 0.64	144.00 0.45
D = 1000 mm [39.37]	L= 1200.00 W= 3.75	800.00 2.50	600.00 1.88	384.00 1.20	274.29 0.86	192.00 0.60
D= 1500 mm [59.06]	L= 1800.00 W= 5.63	1200.00 3.75	900.00 2.81	576.00 1.80	411.43 1.29	288.00 0.90
D = 2000 mm [78.74 in]	L= 2400.00 W= 7.50	1600.00 5.00	1200.00 3.75	768.00 2.40	548.57 1.71	384.00 1.20
D = 3000 mm [118.11 in]	L= 3600.00 W= 11.25	2400.00 7.50	1800.00 5.63	1152.00 3.60	822.86 2.57	576.00 1.80
D = 1 km [3280 ft] ***	L= 1200.00 W= 3.75	800.00 2.50	600.00 1.88	384.00 1.20	274.29 0.86	192.00 0.60

* Full field of view angle and sharp focus may not be achieved if distance is shorter than the given minimum working distance.

** Default slit width (30 µm) and standard NIR detector effective slit length of 9.6 mm used for calculations.

*** Length and width at 1 km calculated in meters [m].



OLN25, OLN50

NIR Lenses Ordering Information		
Part Number	Description	Product Name
MRC-211-001-02	NIR Lens, C-Mount, 8mm f/1.4 (900-1700nm)	OLN8
MRC-211-001-03	NIR Lens, C-Mount, 12mm f/1.4 (900-1700nm)	OLN12
MRC-211-001-04	NIR Lens, C-Mount, 16mm f/1.4 (900-1700nm)	OLN16
MRC-211-001-05	NIR Lens, C-Mount, 25mm f/1.4 (900-1700nm)	OLN25
MRC-211-001-06	NIR Lens, C-Mount, 35mm f/1.4 (900-1700nm)	OLN35
MRC-211-001-07	NIR Lens, C-Mount, 50mm f/1.4 (900-1700nm)	OLN50

SWIR – ENHANCED SERIES

The Enhanced Series SWIR objective fore lenses are optimized for the short-wave infrared wavelength region, 900 – 2500 nm. They have a telecentric output and are optimized for the optics of the Enhanced Series spectrograph, ImSpector N25E.

Optical Characteristics	OLES 15	OLES 22	OLES 30	OLES 56	OLES MACRO
Focal Length	15 mm	22.5 mm	30.7 mm	56 mm	73.3 mm
F-number	2.1	2	2	2	4
Spatial Image Size (max)	9.6 mm	12.8 mm	12.8 mm	9.6 mm	10.0 mm
RMS Spot Diameter	10.0 μm	17.6 μm	16.8 μm	12.9 μm	25.4 μm
Transmission	> 82%	> 82%	> 82%	> 82%	> 82%
Minimum Working Distance *	30 cm	30 cm	30 cm	30 cm	N/A

Mechanical Characteristics

Dimensions	60 mm x \varnothing 45 mm	48.5 mm x \varnothing 47 mm	41.6 mm x \varnothing 53 mm	84 mm x \varnothing 53 mm	173 mm x \varnothing 46 mm
Body Material	Anodized Aluminum	Anodized Aluminum	Anodized Aluminum	Anodized Aluminum	Anodized Aluminum
Mount	C-mount	C-mount	C-mount	C-mount	C-mount

Dimensions of Imaged Line (LxW) at Select Working Distances (D)

Field of View angle (degrees) **	35.5	24.1	17.8	9.8	7.5
D = 100 mm [3.94 in] *	L= --	--	--	--	13.10
	W= --	--	--	--	0.04
D = 300 mm [11.81 in]	L= 192.00	128.00	93.81	51.43	--
	W= 0.60	0.40	0.29	0.16	--
D = 500 mm [19.69 in]	L= 320.00	213.33	156.35	85.71	--
	W= 1.00	0.67	0.49	0.27	--
D = 750 mm [29.53]	L= 480.00	320.00	234.53	128.57	--
	W= 1.50	1.00	0.73	0.40	--
D = 1000 mm [39.37]	L= 640.00	426.67	312.70	171.43	--
	W= 2.00	1.33	0.98	0.54	--
D = 1500 mm [59.06]	L= 960.00	640.00	469.06	257.14	--
	W= 3.00	2.00	1.47	0.80	--
D = 2000 mm [78.74 in]	L= 1280.00	853.33	625.41	342.86	--
	W= 4.00	2.67	1.95	1.07	--
D = 3000 mm [118.11 in]	L= 1920.00	1280.00	938.11	514.29	--
	W= 6.00	4.00	2.93	1.61	--
D = 1 km [3280 ft] ***	L= 640.00	426.67	312.70	171.43	--
	W= 2.00	1.33	0.98	0.54	--

* Full field of view angle and sharp focus may not be achieved if distance is shorter than the given minimum working distance.

** Default slit width (30 μm) and standard SWIR detector effective slit length of 9.6 mm used for calculations.

*** Length and width at 1 km calculated in meters [m].



When choosing between the SWIR Enhanced Series lenses, consider the size of the samples and the desired magnification. The SWIR Enhanced Series offers a range of focal lengths (15 – 56 mm) and field of view angles (9 – 33°). For process applications, a larger field of view angle is generally better because it collects more light and the camera can be placed closer to the sample.

The Enhanced Series SWIR lens OLES MACRO is ideal for imaging very small samples at high resolution. For example, from a working distance of 10 cm, one can view an object that is only 1.2 cm in length.

OLES 15



OLES 56



OLES MACRO



OLES 22



OLES 31



SWIR - Enhanced Series Lenses Ordering Information		
Part Number	Description	Product Name
MRC-308-003-01	SWIR Enhanced, C-Mount Lens. 15 mm f/2, C-mount, E-series, 900-2500nm	OLES15
MRC-308-003-02	SWIR Enhanced, C-Mount Lens. 22.5 mm f/2, C-mount, E-series, 900-2500nm	OLES22
MRC-308-003-03	SWIR Enhanced, C-Mount Lens. 30.7 mm f/2, C-mount, E-series, 900-2500nm	OLES30
MRC-308-003-04	SWIR Enhanced, C-Mount Lens. 56 mm f/2, C-mount, E-series, 900-2500nm	OLES56
MRC-308-003-05	SWIR Enhanced, C-Mount Lens. 1:1 imaging, f/4, C-mount, E-series, 900-2500nm	OLESMACRO

MWIR – ENHANCED SERIES

The Enhanced Series MWIR objective fore lenses are optimized for the mid-wave infrared wavelength region, 3 – 5 μm . They are optimized for the optics of the Enhanced Series spectrograph, ImSpector M50M.

When choosing between the two MWIR Enhanced Series lenses, consider the size of the samples and the desired magnification. For larger objects, the OLEM23 is most appropriate. The mounting of the MWIR lenses have a custom design for use with the MWIR spectrograph in this catalog.

Optical Characteristics	OLEM23	OLEM43
Focal Length	23.4 mm	43 mm
F-number	3	3.8
Spatial Image Size (max)	19.5 mm	18.3 mm
RMS Spot Diameter	11.5 μm	19.0 μm
Transmission	> 94%	> 94%
Minimum Working Distance *	30 cm	30 cm

Mechanical Characteristics

Dimensions	29 mm x \varnothing 28 mm	50 mm x \varnothing 33 mm
Body Material	Stainless Steel / Anodized Aluminum	Stainless Steel / Anodized Aluminum
Mount	Custom	Custom

Dimensions of Imaged Line (LxW) at Select Working Distances (D)

Field of View angle (degrees) **	44.2	24.9
D = 300 mm [11.81 in]	L= 243.59 W= 1.54	132.56 0.84
D = 500 mm [19.69 in]	L= 405.98 W= 2.56	220.93 1.40
D = 750 mm [29.53]	L= 608.97 W= 3.85	331.40 2.09
D = 1000 mm [39.37]	L= 811.97 W= 5.13	441.86 2.79
D = 1500 mm [59.06]	L= 1217.95 W= 7.69	662.79 4.19
D = 2000 mm [78.74 in]	L= 1623.93 W= 10.26	883.72 5.58
D = 3000 mm [118.11 in]	L= 2435.90 W= 15.38	1325.58 8.37
D = 1 km [3280 ft] ***	L= 811.97 W= 5.13	441.86 2.79



* Full field of view angle and sharp focus may not be achieved if distance is shorter than the given minimum working distance.

** Default slit width (120 μm) and length (19 mm) for M50M ImSpector used for calculations. Note that standard detector sizes will limit the effective slit length and change these values.

*** Length and width at 1 km calculated in meters [m]

NOTE: The OLEM23 and OLEM43 have proprietary mounting and are designed to be used with the corresponding MWIR imaging spectrograph.

MWIR - Enhanced Series Lenses Ordering Information

Part Number	Description	Product Name
MRC-308-005-01	MWIR Enhanced Lens. 23.4 mm f/3, custom mount, E-Series, 3000-5000nm	OLEM23
MRC-308-005-02	MWIR Enhanced Lens. 43 mm f/3.8, custom mount, E-Series, 3000-5000nm	OLESM43

LWIR – ENHANCED SERIES

The Enhanced Series LWIR objective fore lenses are optimized for the long-wave infrared region, 8 – 12 μm .

When choosing between the two LWIR Enhanced Series lenses, consider the size of the samples and the desired magnification. The custom mounting of the LWIR lenses are designed for the LWIR cameras in this catalog.



OLEL43

Optical Characteristics	OLEL43	OLEL62
Focal Length	43 mm	61.7 mm
F-number	3.8	2.5
Spatial Image Size (max)	18.4 mm	33.5 mm
RMS Spot Diameter	34.5 μm	23.7 μm
Transmission	> 94%	> 94%
Minimum Working Distance *	30 cm	30 cm

Mechanical Characteristics

Dimensions	50 mm x ϕ 33 mm	56.5 mm x ϕ 46 mm
Body Material	Stainless Steel / Anodized Aluminum	Stainless Steel / Anodized Aluminum
Mount	Custom	Custom

Dimensions of Imaged Line (LxW) at Select Working Distances (D)

Field of View angle (degrees) **	24.2	30.4
D = 300 mm [11.81 in]	L= 128.37	162.88
	W= 0.84	0.58
D = 500 mm [19.69 in]	L= 213.95	271.47
	W= 1.40	0.97
D= 750 mm [29.53]	L= 320.93	407.21
	W= 2.09	1.46
D = 1000 mm [39.37]	L= 427.91	542.95
	W= 2.79	1.94
D= 1500 mm [59.06]	L= 641.86	814.42
	W= 4.19	2.92
D = 2000 mm [78.74 in]	L= 855.81	1085.90
	W= 5.58	3.89
D = 3000 mm [118.11 in]	L= 1283.72	1628.85
	W= 8.37	5.83
D = 1 km [3280 ft] ***	L= 427.91	542.95
	W= 2.79	1.94

* Full field of view angle and sharp focus may not be achieved if distance is shorter than the given minimum working distance.

** Default slit width (120 μm) and max. spatial image size (18.4 mm for OLEL43 and 33.5 mm for OLEL62) of lenses used for calculations. Note that standard detector sizes will limit the effective slit length and change these values.

*** Length and width at 1 km calculated in meters [m]

NOTE: The OLEL43 and OLEL62 have proprietary mounting and are designed to be used with the corresponding LWIR spectral cameras.

LWIR - Enhanced Series Lenses Ordering Information		
Part Number	Description	Product Name
MRC-308-006-01	LWIR Enhanced, Custom Mount Lens. 43 mm f/3.8, Custom Mount, E-Series, 8000-12000nm	OLEL43
MRC-308-006-02	LWIR Enhanced, Custom Mount Lens. 61.7 mm f/2.5, Custom Mount, E-Series, 8000-12000nm	OLEL62